



CPD20L1S

Electric Forklift 2.0T

- Performance improvement of AC motor
- Strength improvement of new mast
- Safety improvement of mechanical braking
- Large battery capacity

EP EQUIPMENT CO.,LTD
www.ep-ep.com

FEATURE

■ Performance improvement of AC motor

All the motors are AC and they provide higher performance.



■ Strength improvement of new mast

CJ mast is applied in this truck thus it is more solid and durable. Moreover, using CJ mast can offer wider view for the driver.



■ Safety improvement of mechanical braking

The truck uses mechanical braking and its braking distance is shorter.



■ Large battery capacity

It is equipped with Li-ion battery and is suitable for high frequency use.



Electric Forklift 2.0T

CPD20L1S

Distinguishing mark	1.1	Manufacturer			EP
	1.2	Model designation			CPD20L1S
	1.3	Drive			Electric
	1.4	Operator type			Seated
	1.5	Load capacity	Q	kg	2000
	1.6	Load center distance	c	mm	500
	1.8	Load distance, centre of drive axle to fork	x	mm	435
	1.9	Wheelbase	y	mm	1470
	Service weight	2.1	Service weight		kg
2.2		Axle loading, laden front/rear		kg	4512/768
2.3		Axle loading, unladen front/rear		kg	1240/2040
Tyres/chassis	3.1	Tyre type			Solid rubber
	3.2	Tyre size, front			200/50-10
	3.3	Tyre size, rear			5.00-8
	3.5	Wheels, number front/rear (x=drive wheels)		mm	2x/2
	3.6	Tread width, front	b10	mm	942
	3.7	Tread width, rear	b11	mm	920
Dimensions	4.1	Tilt of mast/fork carriage forward/backward	α/β	°	6/11
	4.2	Retracted mast height	h1	mm	2080
	4.3	Free lift	h2	mm	105
	4.4	Lift height	h3	mm	3000
	4.5	Height, mast extended	h4	mm	4028
	4.7	Height of overhead guard (cabin)	h6	mm	2080
	4.8	Seat height/standing height	h7	mm	1050
	4.12	Tow coupling height	h10	mm	360
	4.19	Overall length	l1	mm	3315
	4.20	Length to face of forks	l2	mm	2245
	4.21	Overall width	b1/b2	mm	1130
	4.22	Fork dimensions	s/e/l	mm	40×122×1070
	4.23	A,B Fork carriage class/type A, B			2A
	4.24	Fork carriage width	b3	mm	1040
	4.31	Ground clearance, laden, below mast	m1	mm	110
	4.32	Ground clearance, center of wheelbase	m2	mm	105
	4.34.1	Aisle width for pallets 1000×1200 crossways	Ast	mm	3685
	4.34.2	Aisle width for pallets 800×1200 crossways	Ast	mm	3885
	4.35	Turning radius	Wa	mm	2080
Performance data	5.1	Travel speed, laden/unladen		km/h	15/16
	5.2	Lifting speed, laden/unladen		m/s	0.33/0.48
	5.3	Lowering speed, laden/unladen		m/s	0.42/0.45
	5.5	Drawbar pull, laden/unladen		N	—
	5.6	Max. drawbar pull, laden/unladen		N	—
	5.8	Max. gradeability, laden/unladen		%	16/20
	5.10	Service brake			Hydraulic
5.11	Parking brake			Mechanical	
Electric-engine	6.1	Drive motor rating S2 60 min		kW	7
	6.2	Lift motor rating at S3 15%		kW	11
	6.4	Battery voltage/nominal capacity		V/Ah	48/360
	6.5	Battery weight		kg	220
Addition data	8.1	Type of drive control			AC
	10.5	Steering design			Hydraulic
	10.7	Sound pressure level at the driver's ear		dB(A)	73

If there are improvements of technical parameters or configurations, no further notice will be given.
The diagram shown may contain non-standard configurations.

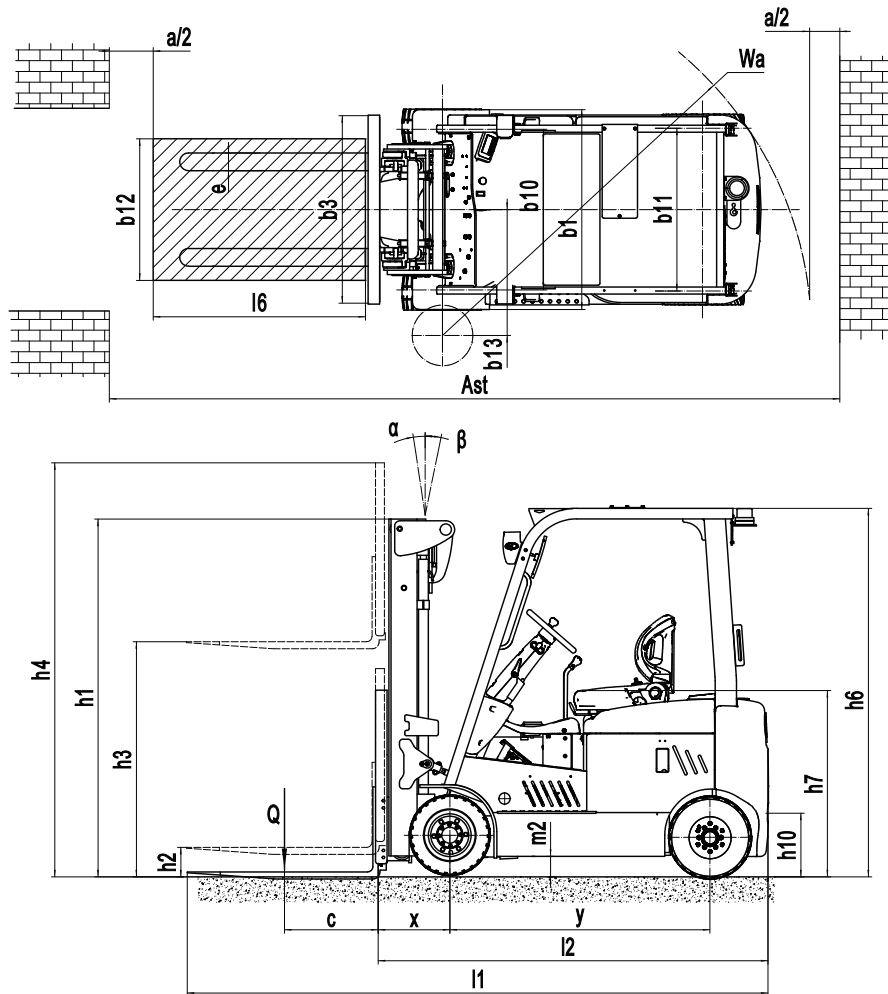

Mast option:

Mast types	Lift height (h3)	Height, Mast			Height, Free lift(h2)	
		Height, mast lowered(h1)	Height, mast extended(h4)		No shelving	With shelving
			No shelving	With shelving		
	mm	mm	mm	mm	mm	mm
2-Standard Mast	2700	1865	3185	3728	120	120
	3000	2015	3485	4028	120	120
	3300	2165	3785	4328	120	120
	3500	2265	3985	4528	120	120
	3600	2315	4085	4628	120	120
	4000	2565	4485	5028	120	120
2-Free Mast	2700	1898	3185	3728	1413	870
	3000	2048	3485	4028	1563	1020
	3300	2198	3785	4328	1713	1170
	3600	2348	4085	4628	1863	1320
3-Free Mast	4350	2030	4844	5378	1536	1002
	4500	2080	4994	5528	1586	1052
	4800	2180	5294	5828	1686	1152
	5000	2245	5494	6028	1751	1217
	5500	2415	6010	6510	1905	1405
	6000	2630	6510	7010	2120	1620

RATED CAPACITIES AND LOAD CENTERES GRAPH

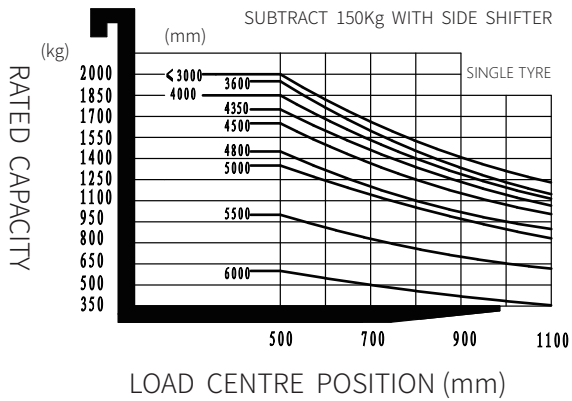

Option:

No.	Optional items	CPD20L1S
1	Fork length	○
2	Folding fork	○
3	Battery capacity	○
4	Import battery	—
5	Solid rubber tire	●
6	Environmental solid tire	○
7	cold storage	—
8	Lateral change battery	—
9	Weighting system with fork	○
10	Overhead guard	○
11	Mast options	○
12	Attachments	○
13	Side shift	○
14	Proportional valve	—
17	Front light	●
28	Back light	○
22	Warning light	●
18	Fire extinguisher	○
19	Water auto-filling system	—
20	Seat	○
21	Seat switch	○
23	With fan heater	○
25	With front windshield wiper	○
26	With rear windshield wiper	○
16	Cockpit	○
24	Doulbe front wheel	—
27	Rearview	●
29	OPS system	○
30	Backrest width	○
31	Side to pull the car	—
32	Air fan	○
33	Charging voltage (220V)	○
35	Drive-in Rack	○

Note: ● standard ○ option — NA