

EP ENERGY

EU24100 Li-ion Battery

- Fits in most electric pedestrian pallet trucks and stackers
- Standard integrated charger for greater charging convenience
- BMS system to maximize the battery lifetime

LI-ION

EP EQUIPMENT CO.,LTD
www.ep-ep.com



FEATURE

■ Fits in most electric pedestrian pallet trucks and stackers

EU24100, EP's 24V100AH lithium battery, features an ultra-slim battery design of 130 mm thickness for a wide variety of electric pedestrian pallet trucks and stacker applications.

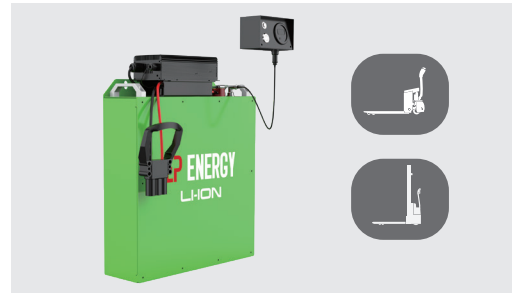

■ Standard integrated charger for greater charging convenience

EP EU24100 lithium battery is equipped with a 24V/30A integrated charger as standard for greater charging convenience on daily usage. A 24V/30A external charger is also available as an option.

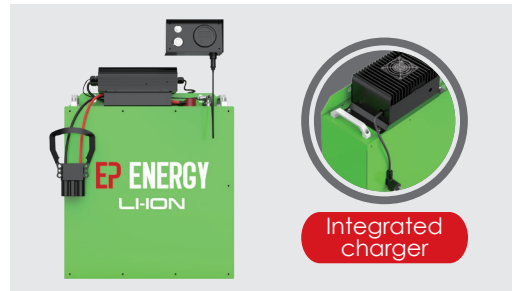

■ Productivity boost with opportunity charging

Operators can take the opportunity of charging during shift breaks. This maximizes uptime. Trucks are always available when needed.

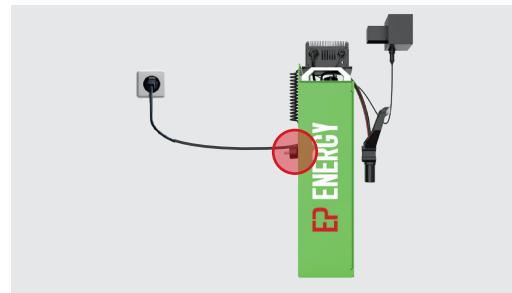

■ Long battery life with less maintenance costs

EP EU24100 lithium battery comes with a naturally long life cycle thanks to Li-ion technology. It is maintenance-free and assures workplace safety with no water filling, air ventilation, and acid spills required.

Battery life span (complete charge and discharge cycles)

Li-ion Battery	Lead-acid Battery
>2000 times	1000 times

■ BMS system to maximize the battery life time

EP's BMS system constantly monitors the status of the battery such as the temperature of the battery cells and it calculates the batteries' state of charge. It keeps the battery in a safe and stable condition.

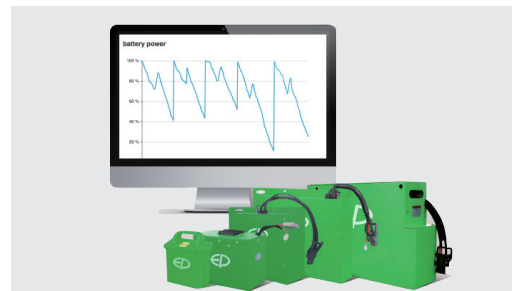

■ Real-time battery monitoring display and power switch

EP EU24100 lithium battery offers a battery indicator which can be equipped in the cabin. Operators can monitor the battery condition in real time and control power supply during an operation.



PARAMETERS

	EU24100
Battery Type	LFP
Battery Color	Green
Nominal Capacity (Ah)	100
Nominal Voltage (V)	24
Standard Charge Current(A)	30
Protection Class	IP54
Battery Weight(kg)	52
Box Dimensions(mm)	450*130*560
Operating Temperature-Discharge(°C)	-20°C-55°C
Operating Temperature-Charge(°C)	0°C-40°C
Charger	24V/30A Integrated (Standard) 24V/30A External (Option)

▣ DIMENSIONS

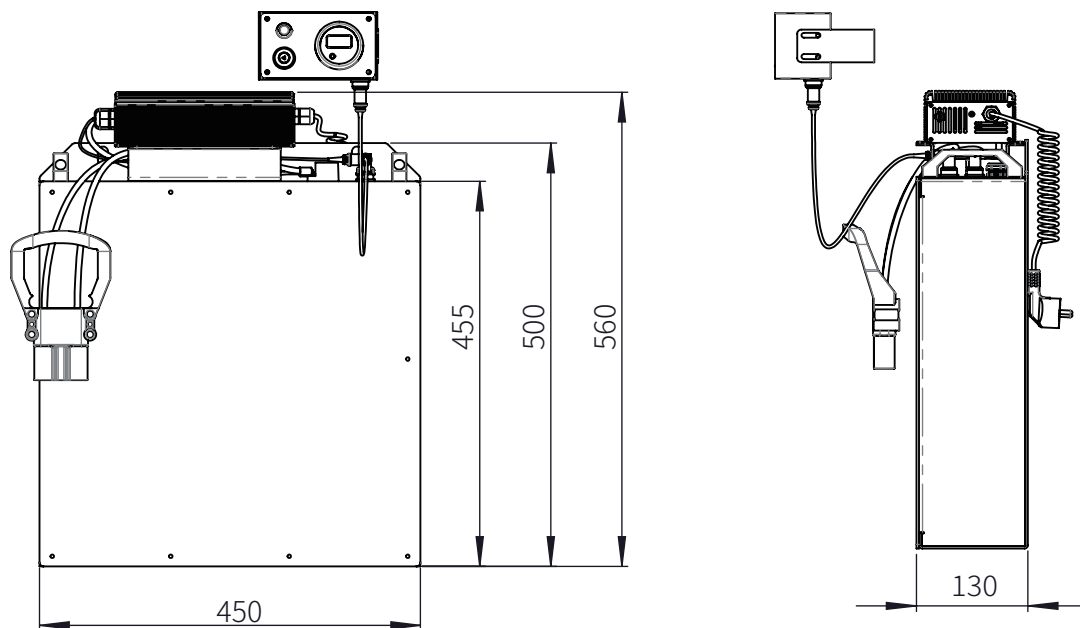

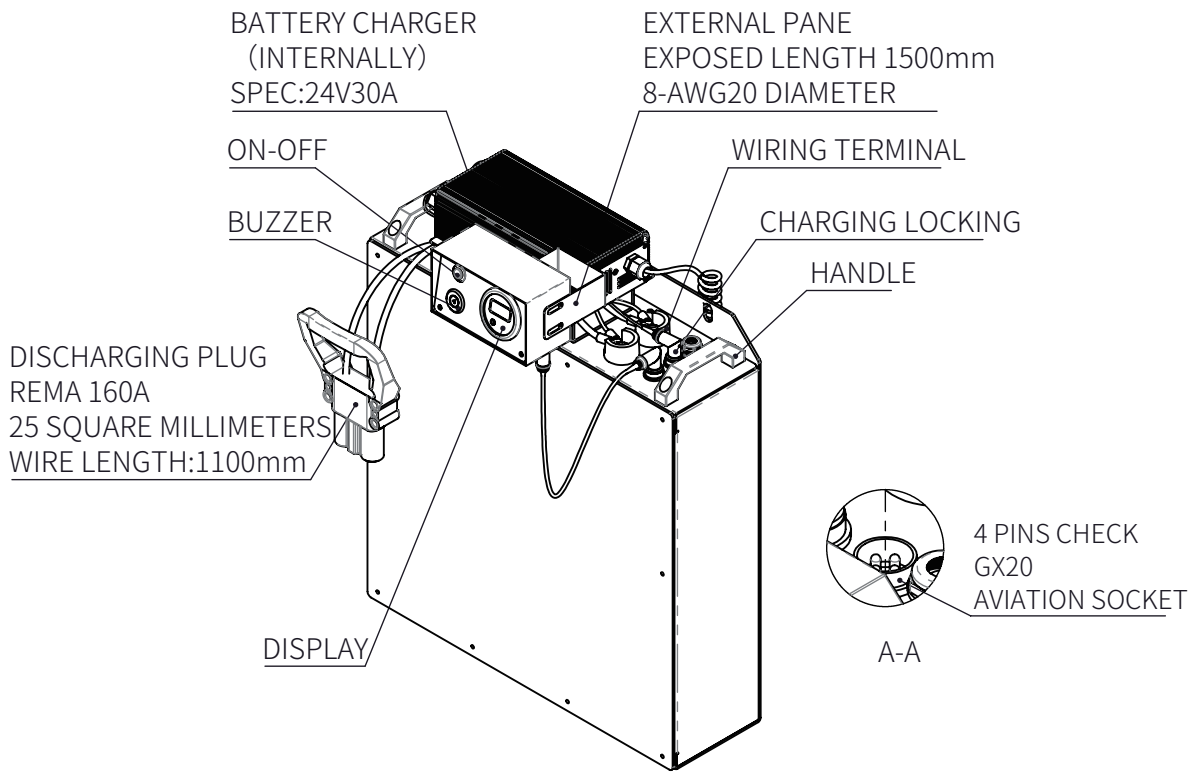

- NOTES:
- 1.WEIGHT:55Kg
 - 2.FINISH:GREEN POWDER COAT
 - 3.SPECIFICATIONS:24V100Ah

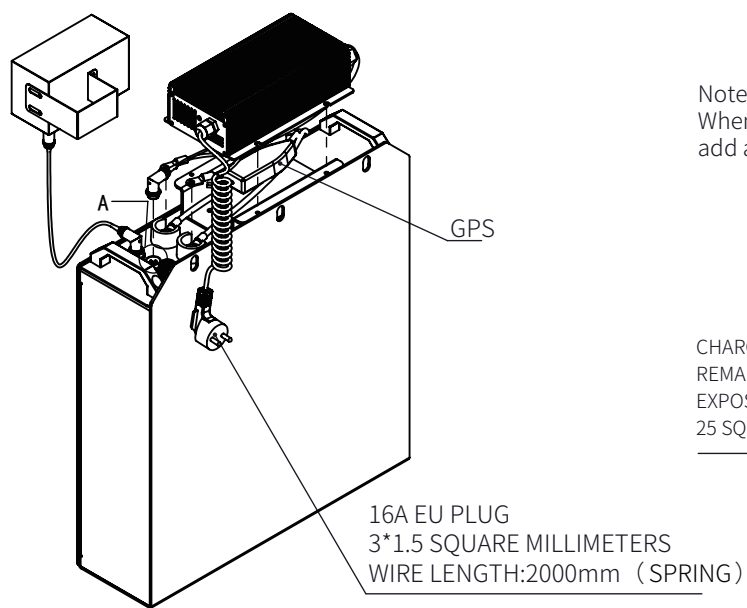
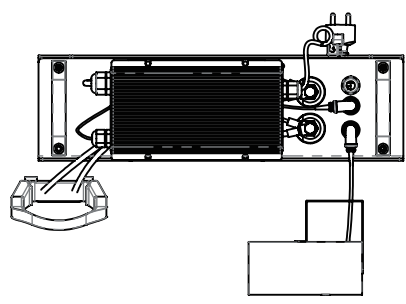

Note:
When connecting an external charger,
add a charging cable

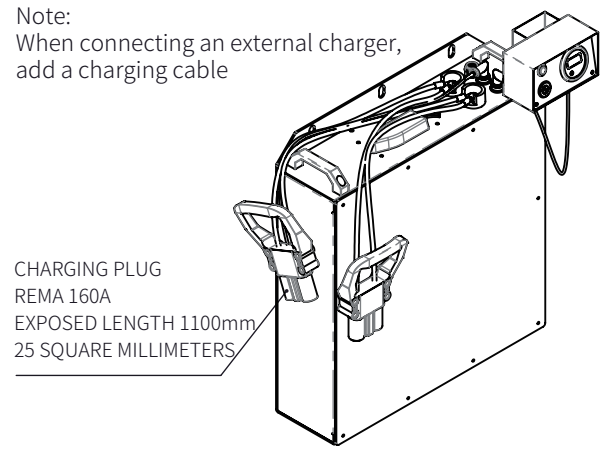

WARRANTY

Save your maintenance effort with EP's superior warranty. Your money will be well spent. For batteries with capacity $\leq 100\text{AH}$: EP Energy provides 24 months or 2,000 hours, whichever comes first, for the battery cell and 24 months for parts.

FAQS »

■ What is the life expectancy of the battery?

Generally, the Lithium ion batteries can live as long as the truck. EP warrants that the Li-ion battery technology will provide you with 2,000 complete charge and discharge cycles and still ensure over 80% of usable capacity. Replacement with Li-ion is not necessary anymore.

■ What happens if we keep charging the batteries? Does it affect battery life?

EP Li-ion battery comes with battery management systems(BMS). When the battery is fully charged, it will automatically power off. This will not affect the lifetime of Li-ion battery. The battery prefers quick charges. So charging during break times is the new normal way of working with batteries.

■ How do Li-ion batteries perform in environment of extreme temperatures?

The batteries can run in relatively extreme temperatures, from minus 20 degrees to up to 55 degrees. The more comfortable the battery feels, the longer its lifetime.

■ Does it affect truck performance when exchanging Lead-acid to Li-ion battery?

No, a truck performance should not be affected by energy supply. EP EU24100 lithium battery is specially designed as Li-ion replacement to the electric pedestrian pallet trucks and stackers from most brands. Just add the counterweight and swap your truck battery, without additional adjustment. There is no change of conditions on driving performance

■ What is BMS system and how does it work?

The BMS plays a crucial role to protect the battery against over and under voltage and over and under temperature. The BMS also balances the cells. This system secures the battery longevity and improves battery performance. Also charging is optimized and charging and discharging cycles are stored in its memory. The data can be read on the display, PC or online with the optional Telematics system.