



EPT20-ET

Electric pallet truck 2.0t

- 48V super power, Ideal out-door solution, Longer run time

Mastering urban logistics

Designed to cope with complex environment



High Obstacle



Road Bumps



Narrow Space

EP EQUIPMENT CO.,LTD
www.ep-ep.com



FEATURE

■ Light service weight, high rated capacity, not limited by floor type:

Minimum size vs 2.0ton capacity,with 1465mm turning radius.

■ High passability design:

EPT20-ET can easily drive through 100mm height barrier with roll-over load wheel and large drive wheel.

80mm lowered height and 140mm lifting height giving flexibility for pallet and application.

■ Easy disassembly handle design:

Pin through tiller style reduces shipping cost and installation time greatly.

■ DC brushless permanent magnet motor:

Life time maintenance free brushless permanent magnet motor.

■ Innovative frame design:

Distribute majority weight to bottom chassis by cylinder structure.

■ Shock absorb chassis design:

Special linkage design, minimize the driving difference between smooth ground and rough ground.

■ 48V electronic system:

48V electronic system increases efficiency and reliability.

■ Easy maintenance:

Electronic system and batteries can be completely exposed by pressing one-touch locker.

Drive wheel can be replaced by loosening one nut.

Retractable charging cord.

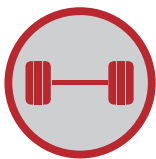

Rated Capacity up to
2000kg

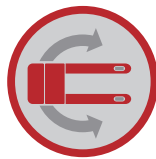

Turning Radius
1465mm



Driving Wheels diameterxwidth
250x74mm



Lowered Height **80mm** | Max Lifting Height **220mm**



Optional Turnable load wheel to overcome obstacle **100mm**
(Note:Only available for EPT16-ET)



Max. gradeability laden/unladen **8% | 16%**

Electric Pallet Truck 2.0t

EPT20-ET

Distinguishing mark	1.1	Manufacturer			EP
	1.2	Model designation			EPT20-ET
	1.3	Drive			Electric
	1.4	Operator type			Pedestrian
	1.5	Load capacity	Q	kg	2000
	1.6	Load center distance	c	mm	600
	1.8	Load distance, centre of drive axle to fork	x	mm	874/962
	1.9	Wheelbase	y	mm	1248/1336
	Service weight	2.1	Service weight		kg
2.2		Axle loading, laden front/rear		kg	722/1498
2.3		Axle loading, unladen front/rear		kg	180/40
Tyres/chassis	3.1	Tyre type			Polyurethane
	3.2.1	Tyre size, front		mm	Φ230x74
	3.3.1	Tyre size, rear		mm	2x Φ78x60
	3.4	Additional wheels (castor wheels)		mm	Φ74x30
	3.5	Wheels, number front/rear (x=drive wheels)		mm	1x 2/4
	3.6.1	Tread width, front	b10	mm	435
	3.7.1	Tread width, rear	b11	mm	410 (535)
Dimensions	4.4	Lift height	h3	mm	140
	4.9	Height of tiller handle in drive position min./max.	h14	mm	750/1170
	4.15	Lowered height	h13	mm	80
	4.19	Overall length	l1	mm	1685
	4.20	Length to face of forks	l2	mm	535
	4.21	Overall width	b1/b2	mm	560 (685)
	4.22	Fork dimensions	s/e/l	mm	50/150/1150
	4.25	Distance between fork-arms	b5	mm	560 (685)
	4.32	Ground clearance, center of wheelbase	m2	mm	30
	4.34.1	Aisle width for pallets 1000×1200 crossways	Ast	mm	2304
	4.34.2	Aisle width for pallets 800×1200 crossways	Ast	mm	2371
4.35	Turning radius	Wa	mm	1550	
Performance data	5.1	Travel speed, laden/unladen		km/h	4/5.5
	5.2	Lifting speed, laden/unladen		m/s	0.018/0.037
	5.3	Lowering speed, laden/unladen		m/s	0.032/0.038
	5.8	Max. gradeability, laden/unladen		%	8/16
	5.10	Service brake			Electromagnetic
Electric-engine	6.1	Drive motor rating S2 60 min		kW	0.75
	6.2	Lift motor rating at S3 15%		kW	0.84
	6.4	Battery voltage/nominal capacity		V/Ah	12*4/30Ah
	6.5	Battery weight		kg	9.5*4
	Additional data	8.1	Type of drive control		
10.5		Steering design			Mechanical
10.7		Sound pressure level at the driver's ear		dB(A)	74

If there are improvements of technical parameters or configurations, no further notice will be given. The diagram shown may contain non-standard configurations.

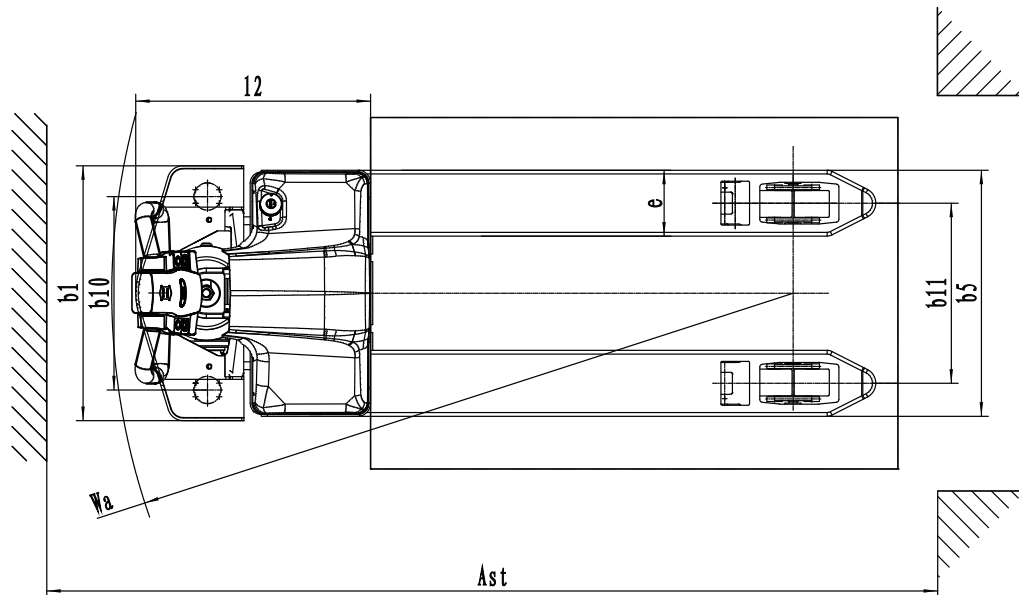
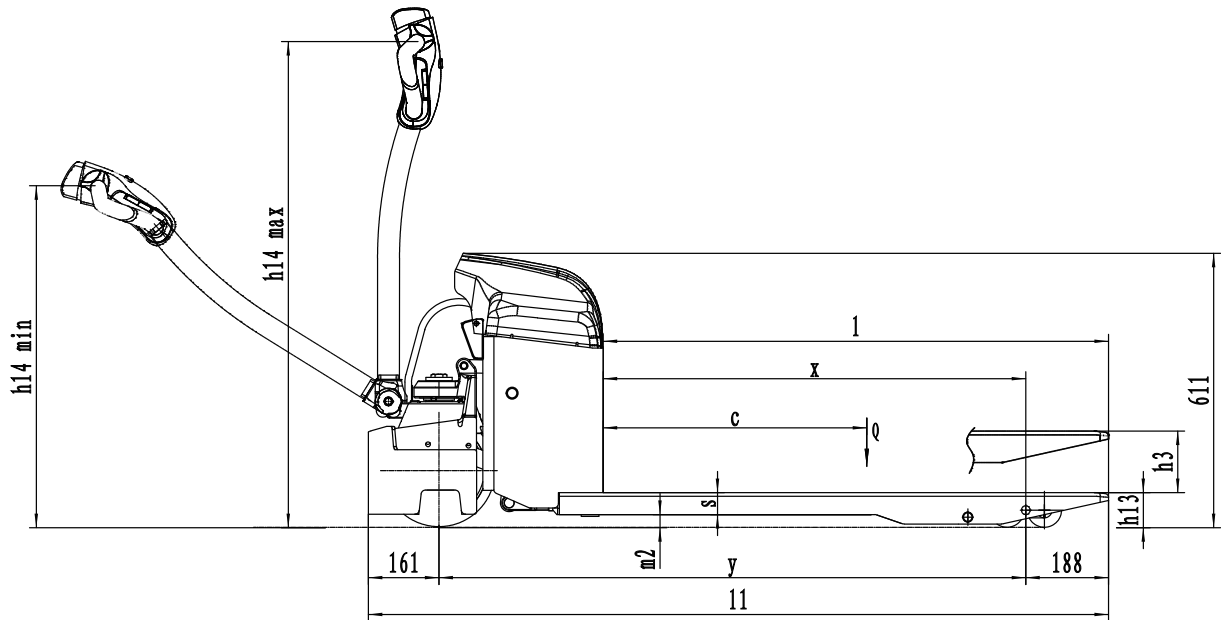

Option

No.	Optional items	EPT20-ET
1.1	Fork dimension	●560*1150、800~2000 ●685*1150、800~2000 ●475*1150、800~2000
1.3	Fork lowered height	●80
2.1	Load wheel type	●Double ○Single
2.2	Load wheel material	●PU
2.3	Drive wheel material	●PU
2.7	Battery capacity	●48V30A
2.8	Charger	●48V-5A Internal
2.9	Battery indicator	●With time
3.3	Castor wheels	●Yes and not customized
3.16	Vertical handler working	●No ○Yes and not customized

Note: ●Standard ○Optional - Inconformity